



8011

Photoelectric Smoke Detector

Characteristics

- Magnetic test feature makes maintenance easy and simple.
- Dual LEDs for 360-degree visibility.
- The standard detector is 2-wire or 3-wire. For 4-wire type just add one relay output module on 3-wire base. Simple and easy module placement enables wider application and flexible stock control.
- Detector is made of high endurance, solid and colorfast Fire-proof plastic.
- Non-loosening screws on base terminal for easy installation.
- Detector has passed strict EMC test, which greatly eliminates false alarms caused by interference from nearby sources.

Approvals: 

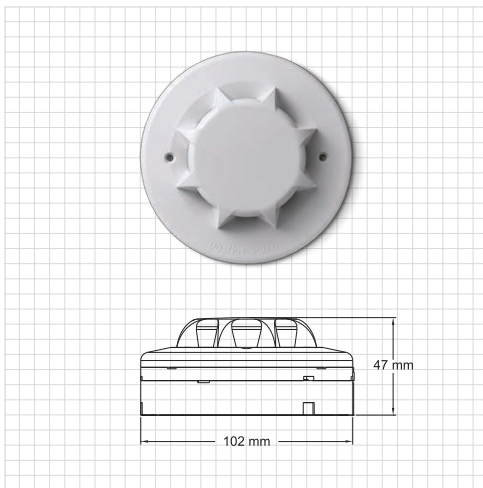

Effective alert area

Building Height	Area Covered
Under 4M	150 M ²
4 ~ 20M	75 M ²

Order information

8011-2	2-wire
8011-3	3-wire with remote indicator output
8011-4	4-wire with relay output
8011-2M	2-wire + magnetic test feature
8011-3M	3-wire with remote indicator output + magnetic test feature
8011-4M	4-wire with relay output + magnetic test feature

Specifications

Model	8011-2	8011-3	8011-4
Alarm Contact	N/A	N/A	0.8A @30V DC 0.4A @125V AC
Voltage Range	12 ~ 30V DC		
Alarm Current @24V DC 470Ω	40mA	40mA	45mA
Standby Current	25 ~ 75μA		
Sensitivity Setting	Comply to EN54		
Ambient Temperature	-10°C ~ +55°C		
Material	Fire-proof plastic		
Dimensions	102mm(Dia.) x 47mm(H)		
Weight	130g	130g	145g
Color	White		